

## Automatic Aerosol Filling Line

### Type Centomat 2018

Capacity: 150 - 600 containers/min

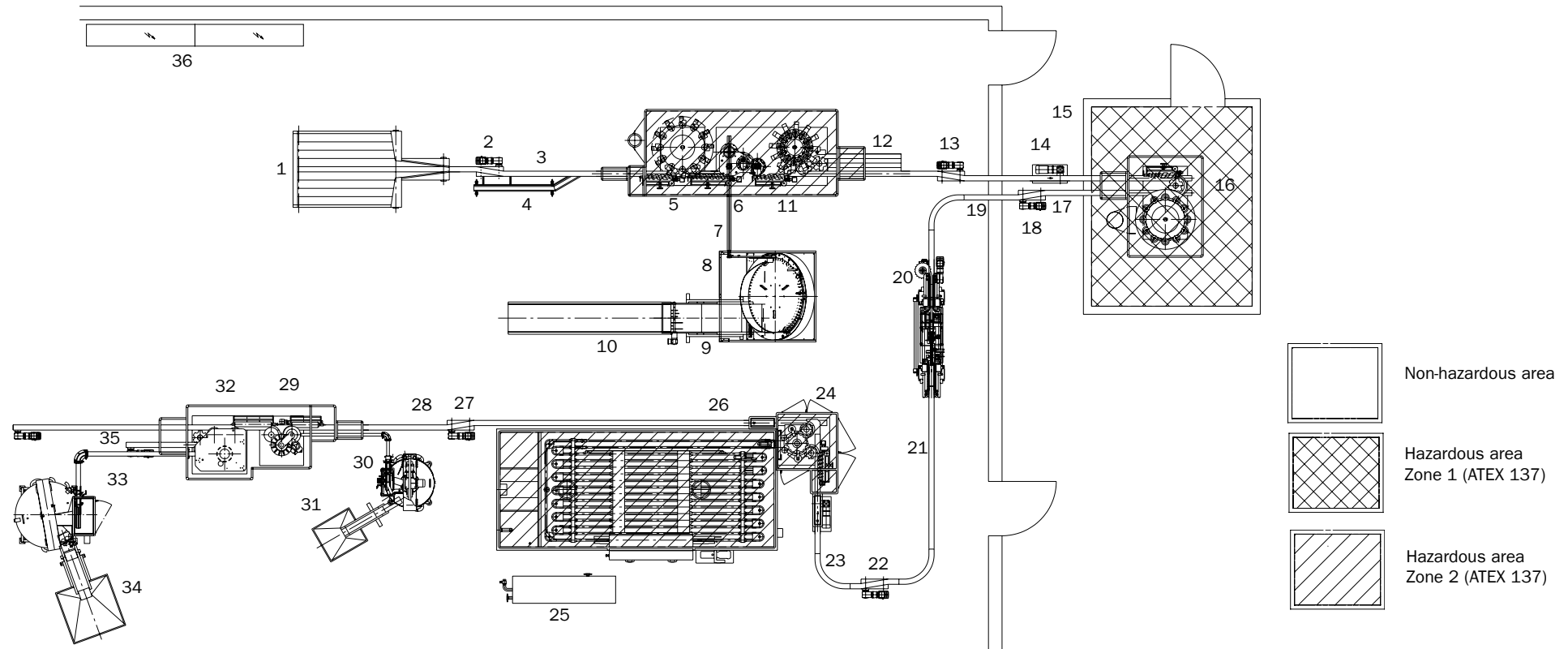

1	Feed Table	9	Valve Elevator	17	Conveyor Belt	23	Conveyor Belt	30	Spray Head Sorter
2	Connection piece	10	Valve Hopper	18	Connection piece	24	Water Bath	31	Spray Head Elevator
3	Conveyor Belt	11	Crimper	19	Conveyor Belt	25	Heater for Water Bath	32	Rotary Capper
4	Loading Table	12	Sampling Table	20	Checkweigher (third party product)	26	Drying Conveyor	33	Cap Sorter
5	Product Filler	13	Connection piece	27	Connection piece	27	Connection piece	34	Cap Elevator
6	Valve Inserter	14	Conveyor Belt	21	Conveyor Belt	28	Conveyor Belt	35	Sampling Conveyor
7	Valve Transport System	15	Gas House	22	Connection piece	29	Rotary Spray Head Inserter	36	Electrical Enclosure
8	Valve Sorter	16	Propellant Filler						